

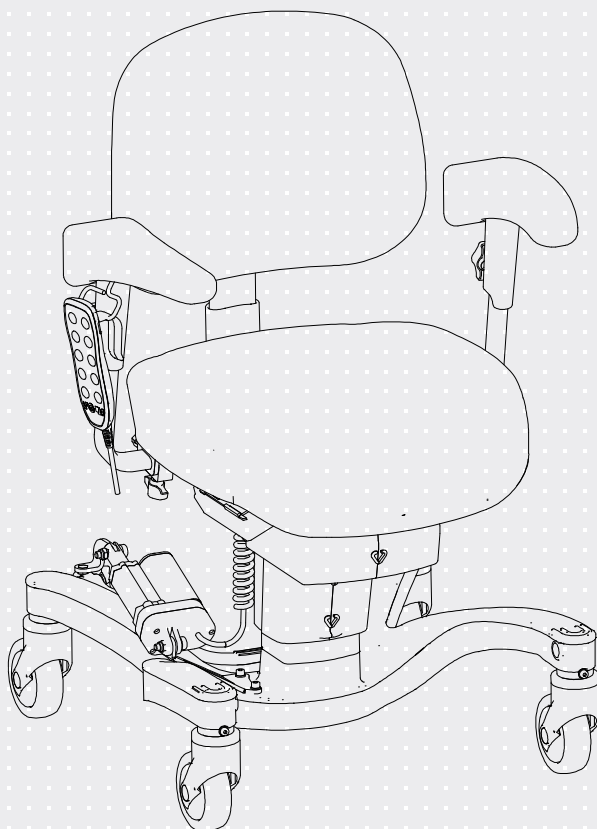

VELA Chair

VERSION: VELA TANGO 700E WITH SIT-TO-STAND FUNCTION

Manual no. 105766



ISO 9001
ISO 14001

CHAIR FUNCTIONS

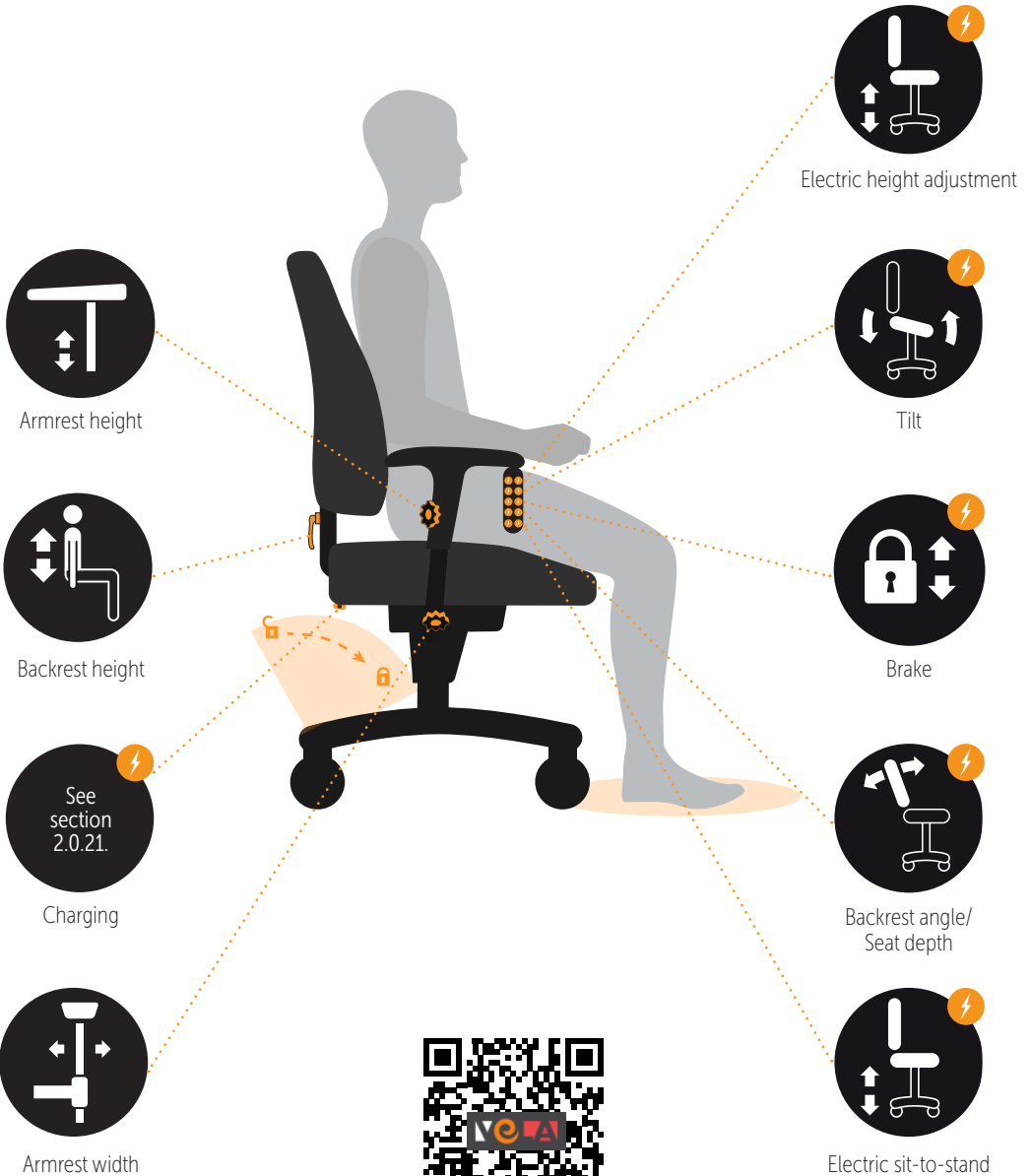

vela.my/trp

HAND CONTROL

How to operate your VELA Tango 700E with sit-to-stand function



SEAT HEIGHT

Adjust your seat height up or down using the arrows. Always set the seat height to match the activity you are performing.

SEAT TILT ADJUSTMENT

The entire seating unit (seat and backrest) moves together. Adjust the seat tilt forward or backward using the arrows until you feel secure in your activity.

BRAKE

The electric brake is engaged and released using the buttons. The chair always applies the brake when you stand up or sit down using the sit-to-stand function.

BACKREST ANGLE ADJUSTMENT

Adjust the backrest forward or backward using the arrows. Set the backrest to a position where you feel comfortable.

SIT-TO-STAND FUNCTION

The brake locks, and the seat tilt, backrest angle, and seat height adjust automatically. Pressing the up arrow supports you in standing up safely, while pressing the down arrow assists in sitting down securely.*

The sit-to-stand function can be customised to your needs. Instructions on page 18.

*This sit-to-stand function has memory, allowing the user to pause the sequence for up to one minute while adjusting their sitting position, and then resume the sequence. The sequence will be canceled if paused for more than a minute or if other buttons are pressed. If canceled, the chair will move into neutral position before a new sequence can begin.

TABLE OF CONTENTS

1.0. INTRODUCTION	5
1.1. WARNINGS	6
1.2. TROUBLESHOOTING	7
1.3. VELA TANGO WITH ELECTRIC HEIGHT ADJUSTMENT	8
1.3.1. Power input	8
1.3.2. Emission	8
1.3.3. Surge protection	8
1.4. LABELS USED ON THE CHAIR	9
1.5. SAFETY	9
1.5.1. Intended use	9
1.5.2. Transport	10
1.6. WARRANTY	10
1.7. UNPACKING THE CHAIR	10
1.8. MAINTENANCE	10
1.8.1. Wheels	11
1.8.2. Frame	11
1.8.3. Padding	11
1.8.4. Recycling guide	11
1.9. RECYCLING AND DISPOSAL	11
2.0. SETTINGS	12
2.0.1. Attaching the backrest	12
2.0.2. Hand control	12
2.0.3. Adjust the sitting height	12
2.0.4. Setting angle of backrest	13
2.0.5. Adjustment of seat tilt	13
2.0.6. Electric brake	13
2.0.7. Sit-to-stand function	13
2.0.8. Adjustment of seat depth	14
2.0.9. Setting the back height	14
2.0.10. Back bolt	14
2.0.11. Adjusting lumbar support*	14
2.0.12. Adjusting the armrest height	15
2.0.13. Adjusting the armrest width	15
2.0.14. Fold-down armrest*	15
2.0.15. Changing the seat	15
2.0.16. Folding footrest*	16
2.0.17. Side-mounted swivel footrest*	16
2.0.18. Push bar*	16
2.0.19. 4-wheel brake*	16
2.0.20. Fold-down holder for hand control*	17
2.0.21. Charging	17
2.0.22. Accessories	17
2.1. CUSTOMIZE SETTING	18
2.1.1. Customize your neutral Seating Position	18
2.1.2. Customize your Sit-to-stand position	18

1.0. INTRODUCTION

DEAR CUSTOMER

Congratulations on your new VELA Tango 700E Chair with Sit-to-stand function! We are sure this chair will give you daily pleasure. This user manual provides useful information on adjusting, operating and maintaining your chair.

Important

Please read this user manual carefully and keep it safe for when you need to refer to it. This manual is also available on www.vela.eu, where you can also find other relevant information.

If you have questions, experience errors or adverse events, please contact your VELA supplier.

We reserve the right to make changes.

VELA

Gøteborgvej 8-12
DK-9200 Aalborg SV
Denmark
www.vela.eu

1.1. WARNINGS



Use	In case of an allergic reaction, stop using the chair and consult a doctor
Use	Only use original spare parts from VELA
Use	Only use the supplied charger for charging the chair
Use	Do not make any changes to the accessories that come with the chair
Use	Only use the chair for the intended purpose
Use	Only adjust the seat angle and backrest angle while the user is sitting in the chair and the user's feet are flat on the floor
Use	Always have the chair brake on when you sit down or get up
Use	On smooth surfaces such as highly polished floors or marble tiles, the chair may slide. Here, it is recommended to use a 4-wheel brake
Use	Never use the chair on uneven surfaces, including areas with level differences or loose carpets, as this may pose a risk of the chair becoming unstable
Use	Maintenance other than cleaning should always be performed by a professional
Use	Never service the chair while it is in use
Use	Always follow the recommended maintenance and cleaning instructions
Use	The chair's functions are intended for the user. Only the user or trained professionals should adjust the chair while the user is sitting in it
Use	Never use the electric height adjustment for more than two minutes at a time
Use	Risk of shearing or squeezing fingers in moving parts. Therefore, never use the chair if someone is touching underneath the seat
Choking hazard	Choking hazard on small parts. Never allow children to play with the chair, as small parts are removable
Choking hazard	If the chair is equipped with electric height adjustment, cables will be present. Never let children play with these
Electrical disturbances	Using cables other than the standard ones may increase electrical emission or decrease electrical immunity
Electrical disturbances	Portable RF communication equipment (including antennas) may affect the performance of this device. Such equipment should be used no closer than 30 cm (12 inches) to any part of the device or its cables, unless otherwise specified by VELA.
Electrical disturbances	The chair may only be used with accessories mentioned in this user manual, as electro-magnetic interference may otherwise occur
Electrical disturbances	If the chair moves unintentionally or does not work as expected, find another location for the chair

1.2. TROUBLESHOOTING

Mistake	Possible cause and solution
Electric height adjustment does not work	The plug is not in the armrest – plug it in There is no power on the chair's battery. Charge the battery with the supplied charger The fuse is broken. See section 1.3.3 Perform a reset of the actuator. Hold both height adjustment buttons (up and down) simultaneously for 20 seconds. Keep holding the buttons until the actuator has fully retracted and then moved approximately 5 mm up again.
The brake function does not work	The brake is not activated. See section 2.0.6. and/or 2.0.19.
The armrest seems loose	One of the hand screws might be loose. Tighten the hand screw
The chair rolls badly	Wheels are blocked. Clean the wheels for wire residue and the like.



If the above does not solve your problem, you should contact your VELA supplier.

1.3. VELA TANGO WITH ELECTRIC HEIGHT ADJUSTMENT

1.3.1. POWER INPUT

Voltage: 24Vdc

Current: 0.5A

Power: 12VA

1.3.2. EMISSION

A VELA chair with electrical functions has been tested and complies with current requirements regarding electromagnetic radiation (EMC requirements). The chair is tested to the following specifications:

:: Emission class CISPR 11, Group 1, Class B

See more details at www.vela.eu

1.3.3. SURGE PROTECTION

A fuse is installed on the chair which secures the chair against power surges. The replaceable part of the fuse has the following specifications:

:: Flat fuse, type: ATOF blade fuse, fast-acting

:: Voltage: 32V



:: Current: 10A

:: Max. current: 1000A

Replacement of the fuse may only be performed by professionals, as the cause of the breach must be documented for safety reasons.

IN GENERAL

1.4. LABELS USED ON THE CHAIR

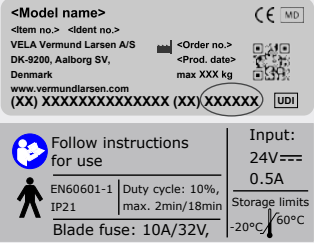
Warning	Risk of shear and squeeze: Keep hands and fingers away from moving parts	
Icon	Read "Instruction For Use" before use	
Icon	Part used: Type B cf. IEC60601-1 covering the following areas of the chair:	
Labels	60 x 22.5 mm The last six digits are the product ID number: This label only applies to chairs with electrical functions: The chair is IP21 approved, which corresponds to protection against water droplets as well as against touching dangerous parts with a finger.	 <p> <Model name> <Item no.> <Ident no.> VELA Vermund Larsen A/S DK-9200, Aalborg SV, Denmark www.vermundlarsen.com (XX) XXXXXXXXXXXXXXXX (XX) XXXXXX </p> <p> CE MD <Order no.> <Prod. date> max XXX kg UDI </p> <p> Follow instructions for use EN60601-1 Duty cycle: 10%, IP21 max. 2min/18min Blade fuse: 10A/32V, </p> <p> Input: 24V= 0.5A Storage limits -20°C / 60°C </p>

Labels on the chair should be read at a distance of approx. 40 cm under normal daylight conditions.

For labels related to the operation of the chair, please refer to section 2.0.

1.5. SAFETY

This chair is CE marked and complies with applicable EU regulations. The chair is manufactured by: VELA, Gøteborgvej 8-12, DK-9200 Aalborg SV, Denmark.

The VELA Tango with electrical functions meets all safety requirements according to IEC 60601-1, including requirements for EMC according to IEC60601-1-2.

1.5.1. INTENDED USE

This device is intended to support a user in a sitting posture while performing indoor activities of daily living including work activities.

- :: The chair is not built to stand on
- :: The wheel brake must always be activated when sitting down or standing up

All variants of this chair are tested and approved for a maximum load of 160 kg. For optimal use, the chair's recommended user weight is 50-145 kg with electric height.

Note: Persons using a harness in the chair must always be supervised when the harness is in use.

1.5.2. TRANSPORT

When transporting the chair by car, airplane or any other means of transport, always use the chair brake. The chair is not approved for use as a passenger seat in any means of transportation and may not be used as such.

The chair is designed to be transported under the following environmental conditions:

Temperature: - 20°C to + 60°C
Humidity: 15-95%

Allow the chair to stand for 24 hours before use if it has been stored below - 10°C.

1.6. WARRANTY

VELA grants a right of claim under applicable law in the country where the chair is acquired. The right of complaint applies only when using original spare parts and accessories, as well as customisations made by professionals.

Note: if an exclusive contractual agreement has been made directly with VELA, this applies!

VELA assumes no liability for damages to the product or the user

caused by:

- :: Transportation
- :: Misuse
- :: Normal wear and tear
- :: Wrong use
- :: Use of spare parts and accessories that are not original VELA products
- :: Adjustments made by unauthorised service technicians

1.7. UNPACKING THE CHAIR

The chair comes in environmentally friendly and recyclable packaging.

In case of defects or transport damage to the chair, please contact your VELA supplier right away. In such cases, do not attempt to use the chair or to fix it yourself.

On delivery you have received:

- :: VELA chair
- :: Instructions for use
- :: Charger (only for chairs with electrical functions)

Note: see item 2.0.1 for correct attachment of backrest.

1.8. MAINTENANCE

We recommend an annual inspection of the chair to identify any defective or worn parts. All removable parts should be tightened regularly. You can find various guides on www.vela.eu.

1.8.1. WHEELS

We recommend you regularly check the wheels and remove any residual threads, etc. Certain floor types accumulate dirt on the castors. Therefore, clean the castors as needed.

1.8.2. FRAME

Clean with lukewarm water and if necessary, add some pH-neutral detergent.

1.8.3. PADDING

Fabric: Clean by chemical cleaning, with furniture cleaner or with water using a hard-wrung cloth.

Synthetic fabric or leather: Clean with water or mild soap using a hard-wrung cloth.

Leather: Clean by vacuuming with a soft brush. Avoid using detergent.

Note: On www.vela.eu you can find cleaning instructions for all our standard upholstery types.

1.8.4. RECYCLING GUIDE

Your VELA chair can be reused by another person when you no longer need it as long as the chair is serviced by a technician beforehand.

The chair's life expectancy is five years for regular and proper use. We recommend that VELA, your VELA supplier or a trained professional perform an annual inspection with the replacement of worn parts.

1.9. RECYCLING AND DISPOSAL

This product contains recyclable materials. Therefore, the product must be disposed of in accordance with local regulations and not together with ordinary household waste. Proper disposal and recycling will help prevent negative effects on the environment and people.

Note: Electrical and electronic equipment and accompanying batteries contain materials, components and substances that can be harmful to human health and the environment if the waste is not handled properly.

Electrical and electronic equipment and batteries are marked with the icon shown below. This symbolises that electrical and electronic equipment and batteries must not be disposed of together with unsorted household waste but must be collected separately.



It is important that you return your used batteries to the established schemes. In this way, you help ensure that batteries are recycled in accordance with current legislation and do not cause unnecessary harm to the environment.

2.0. SETTINGS

The electric lifting mechanism should only be replaced by a VELA technician or a person trained in this field.



2.0.1. ATTACHING THE BACKREST

The backrest is lowered into the hole. Screw the handle back on and tighten securely.

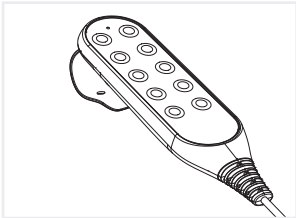
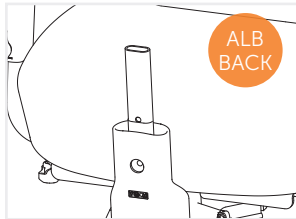

2.0.2. HAND CONTROL

The hand control is used via push buttons on the front. The icons on the hand control show the button functions.

Note: Electrical functions should only be used continuously for one minute, then a nine-minute break should follow.

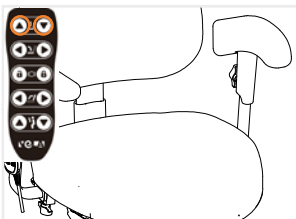

2.0.3. ADJUST THE SITTING HEIGHT

The sitting height changes up and down. Adjust using the buttons on the hand control. Adjust so the height fits the users activity og location.

Note: The placement of a specific function may vary on different hand controls, please check the icon before use.

Note: Setting the angle of backrest and seat should always be done with your feet flat on the floor.

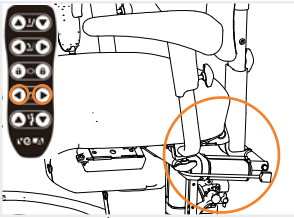

2.0.4. SETTING ANGLE OF BACKREST

The backrest moves independently. Adjust using the buttons on the hand control. Adjust it so that the backrest angle suits the user of the chair. **Note:** The placement of a specific function may vary on different hand controls, please check the icon before use.

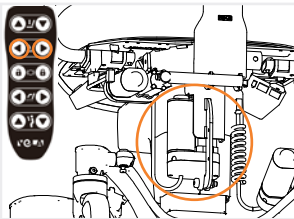

2.0.5. ADJUSTMENT OF SEAT TILT

The entire seating unit moves (seat and backrest together). Adjust using the buttons on the hand control. Adjust it so that the seat angle suits the user of the chair. **Note:** The placement of a specific function may vary on different hand controls, please check the icon before use.

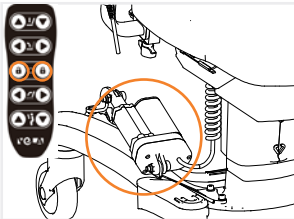

2.0.6. ELECTRIC BRAKE

The electric brake is activated and deactivated. Adjust using the buttons on the hand control. It is advisable to activate or deactivate the brake completely when using this feature. Can also be used together with the 4-wheel brake (see section 2.0.19.) **Note:** The placement of a specific function may vary on different hand controls, please check the icon before use.

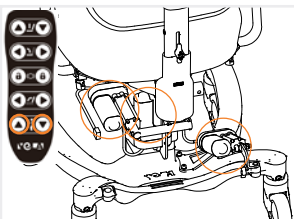

2.0.7. SIT-TO-STAND FUNCTION

The brake locks, and the seat tilt, backrest angle, and sitting height adjust. It assists in standing up and sitting down. It can be set to an optimal exit position and a neutral sitting position (see section: 2.1.1-2.1.2.). **Note:** This sit-to-stand function has memory, allowing the user to pause the sequence for up to one minute* while adjusting their sitting position, and then resume the sequence.

* The sequence will be canceled if paused for more than a minute or if other buttons are pressed. If canceled, the chair will move into neutral position before a new sequence can begin.

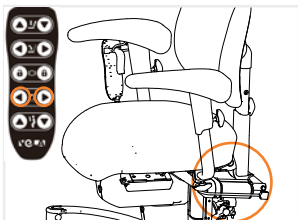

2.0.8. ADJUSTMENT OF SEAT DEPTH

Adjust using the buttons on the hand control. Adjust the backrest so that the seat depth suits the user of the chair. **Note:** The placement of a specific function may vary on different hand controls, please check the icon before use.

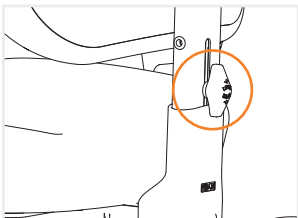

2.0.9. SETTING THE BACK HEIGHT

Release the handle located on the back. Adjust the back. Remember to tighten the handle afterwards.

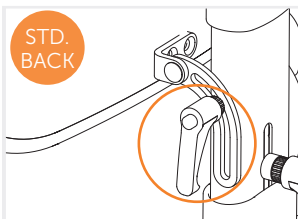

2.0.10. BACK BOLT

The backrest can be set to a specific angle by adjusting and attaching the bolt mounted on the back of the backrest.

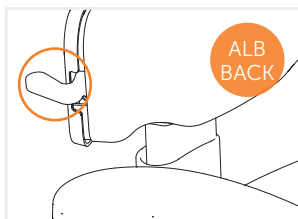

2.0.11. ADJUSTING LUMBAR SUPPORT*

The backrest can be adjusted to provide optimal lumbar support by pulling up the handle on the right-hand side of the backrest. The backrest adjusts to fit and support the lower back. Release the handle, and the backrest remains in the desired lumbar angle.

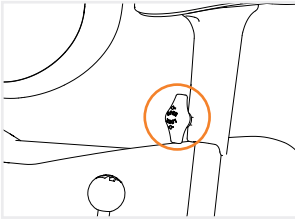

2.0.12. ADJUSTING THE ARMREST HEIGHT

Adjusted by loosening the screw on the armrest bar and adjusting the height of the armrest. Remember to tighten the screw when done.

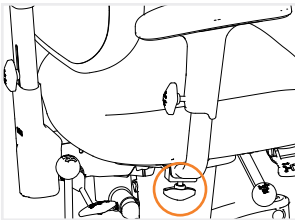

2.0.13. ADJUSTING THE ARMREST WIDTH

Adjusted by loosening the screw under the seat on the seat support and adjusting the armrest width by pulling out the armrest. Remember to tighten the screw when done.

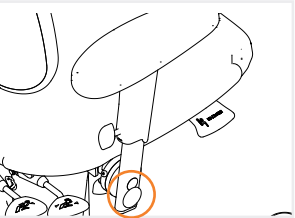

2.0.14. FOLD-DOWN ARMREST*

To fold down the armrest, press the button on the side of the armrest and push the armrest backwards and down.

Note: The armrest is only locked when it is in an upright position. The armrest can only be folded down if the width adjustment of the armrest allows it.

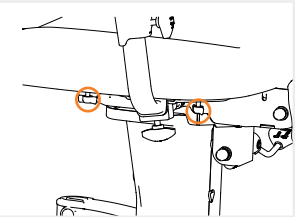

2.0.15. CHANGING THE SEAT

The seat can be replaced by removing the four thumbscrews that are located in each corner under the seat.

* Accessory

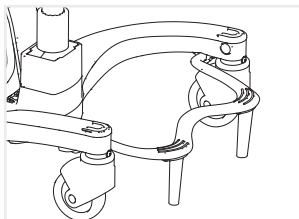

2.0.16. FOLDING FOOTREST*

Stabilising foot support that can also be used as a footboard when moving in and out of the chair.

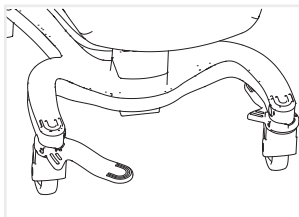

2.0.17. SIDE-MOUNTED SWIVEL FOOTREST*

Mounted on the underside of the front right and/or left chair legs, the footrest can be turned in/out and provide support for a leg as needed. Once the footrest is inside, it is tucked away under the chair frame. The footrest has a rotation stop in both the inner and outer positions.

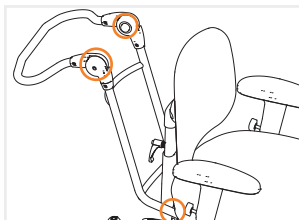

2.0.18. PUSH BAR*

Push bar for transporting a person in the chair. The push bar is mounted to fittings under the seat using two finger screws. This is also where the depth is adjusted. The height is adjusted by pressing the two buttons on the side of the push bar while the handle is positioned at the desired height.

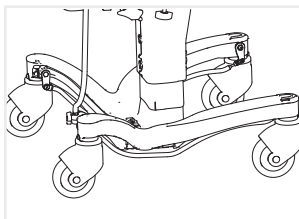

2.0.19. 4-WHEEL BRAKE*

Is activated via hand control or switches. 4-wheel brake brakes on all wheels and provides a stable seat on uneven/skewed surfaces. **Note:** On the electric version it is advisable to activate or deactivate the brake completely when using this feature.

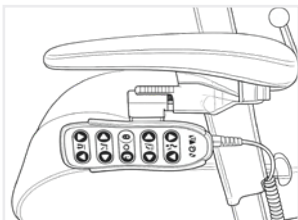

2.0.20. FOLD-DOWN HOLDER FOR HAND CONTROL*

Horizontal position: Gently push the holder forward to unlock it and fold it down. Vertical position: Lift the holder upward, and it locks in the horizontal position.

Gently pull the hand control forward while turning it to remove it. Place the hand control in the holder and push it backward to secure it again.

vl1935.dk/charge



2.0.21. CHARGING

Charge every day. The chair is charged by plugging the charger into the switch placed under the seat on the rear-left side. The charger is plugged into an electrical outlet. An LED will light yellow while the chair is charging and green when it is fully charged. Remember to remove the charger before use. Note: The chair must not be used during charging.

2.0.22. ACCESSORIES

This chair is available with a wide range of accessories. See a complete list of accessories at: www.vela.eu

Note: Charger is included as an accessory when purchasing a VELA chair with electrical functions.

* *Accessory*

2.1. CUSTOMIZE SETTING

Note: If needed, get guidance from a therapist to set an optimal seating position and sit-to-stand position.



2.1.1.: CUSTOMIZE YOUR NEUTRAL SEATING POSITION

Make sure the chair is locked! Adjust the seat height, seat tilt, and backrest angle so that you are sitting comfortably and stably with your feet flat on the floor. Once the chair is adjusted, press the two buttons at the bottom right for five seconds. When you hear a click, the setting is saved.

2.1.2.: CUSTOMIZE YOUR SIT-TO-STAND POSITION

Make sure the chair is locked! Adjust the seat height, seat tilt, and backrest angle so that you are standing comfortably and stably with your feet flat on the floor. Once the chair is adjusted, press the two buttons at the bottom left for five seconds. When you hear a click, the setting is saved.



Perform a reset of the actuator. Hold both height adjustment buttons (up and down) simultaneously for 20 seconds. Keep holding the buttons until the actuator has fully retracted and then moved approximately 5 mm up again.

GETTING STARTED

- 1 Brake the chair and sit back in the seat.
- 2 There should be about 3 cm between the seat cushion and the back of your knees.
- 3 Adjust the seat angle and height so that you sit comfortably with your feet flat on the floor.
- 4 Adjust the backrest height and angle to adjust the seat depth and support your lower back and back.
- 5 Adjust the armrest width and height so that your forearms rest on the armrest pad.

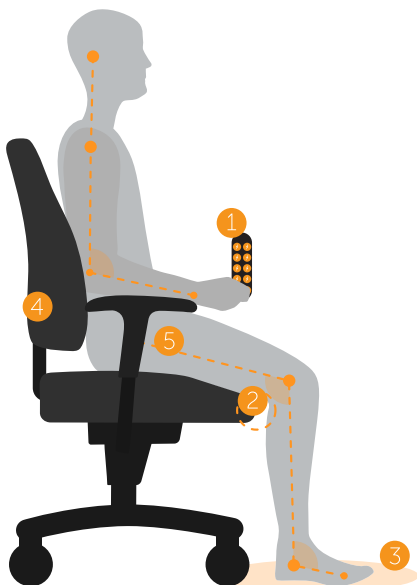

vela.my/GetStarted